

Caframo® LabSolutions

6015 Ultra Speed

Create accurate repeatable results through high speed mixing and precision with Caframo's Ultra Speed. Maintain consistent set speeds up to 6000 rpm under changing viscosities with digital display and control.

Depend on the quiet, high efficiency brushless DC motor. Benefit from the Ultra Speed's built in safety features including a clear chemical resistant chuck guard and overload protection.

Key Specifications:

- | | |
|---------------|---------------------|
| Speed Range | • 40 - 6000 rpm |
| Max Torque | • 170 Ncm |
| Max Viscosity | • 20,000 cP |
| Output Power | • 1/5 hp, 150 watts |
| Max Volume | • 25 litres |

Accurate
Dependable
High Speed Precision



6015 Ultra Speed

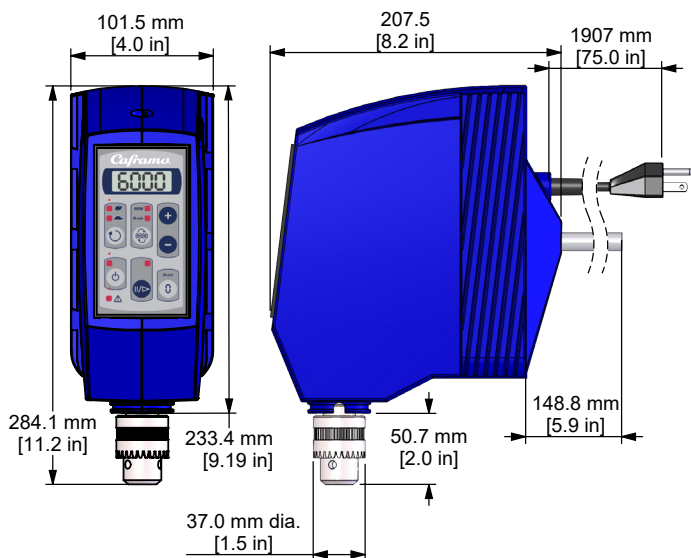

Additional Specifications:

Input Power	120 volts, 60 Hz or 220-240 volts, 50/60 Hz
Motor	Brushless DC
Weight	6.82 kg
Display	Digital display, keypad
Mounting	12.5 mm dia support rod
Impeller Adjustment	Through shaft
Impeller Attachment	Keyed chuck, accepts shafts up to 10 mm dia
Includes	Calibration certificate, chuck, chuck guard, chuck key, support rod and power cord
Approvals	CSA listed to Canada and US standards.
Warranty	Three years

Features and Benefits:

Digital Control

- Digital display of rpm and torque
- User friendly keypad allows precise speed adjustment
- Maintains set speed as solution viscosity changes

Chuck Guard

- Protects chuck from splashing
- Encloses spinning chuck
- Value in workplace safety

Quality and Value

- Overheat and overload protection
- Quiet operation
- 3-year warranty

Applications:

- Cosmetics formulation
- Inks and paints
- Pharmaceutical products
- Food
- Polymers

Create a
Textbook
Vortex!



Dispersion of ceramic powders

Caframo[®]
LabSolutions

1-800-567-3556 ext 248
CaframoLabSolutions.com
501273 Grey Road 1, Georgian Bluffs ON N0H 2T0 Canada